

BALANCING MACHINES FOR THE **AEROSPACE** INDUSTRY

CEMB balancing machines for the aerospace industry comply with SAE standards and are designed for applications in OEM production lines and MRO maintenance centers. They ensure repeatability, operator safety, and advanced analysis for the aerospace industry thanks to dedicated software.

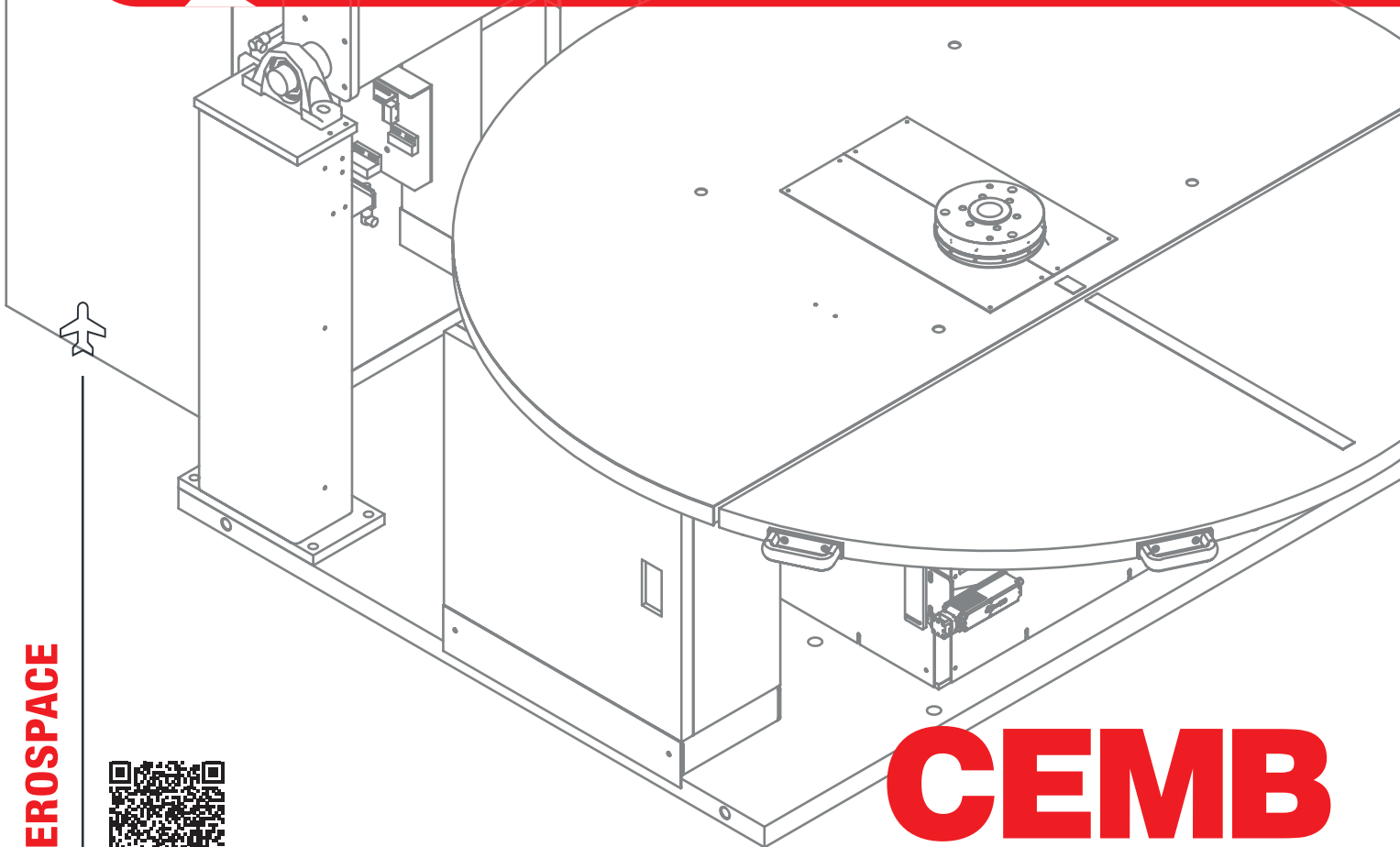

AEROSPACE



CEMB
BALANCING MACHINES

VERTICAL-AXIS BALANCING MACHINE FOR AEROSPACE ROTORS

FEATURES

- Unbalance measurement according to SAE ARP4050 and ARP4162, suitable for high-speed rotating components with minimal tolerances.
- Optimal vertical configuration for turbines, discs, compressors, propellers, and turbofans. It ensures perfect centering and process repeatability, even for complex geometries.



TECHNICAL DATA

	V30 AERO	V50 AERO	V100 AERO	V200 AERO	V500 AERO
Maximum rotor weight + tooling (kg-lb)	30-65	50-110	120-260	250-550	500-1100
Maximum rotor diameter (mm-inches)	635-25	1200-47	1500-59	1780-70	2160-85
Maximum rotor height (mm-inches)	254-10	900-35	510-20	770-30	770-30
SAE master (lb)	25	25	80	250	250
Machine SAE class	50	100	250	500	1000

HORIZONTAL-AXIS BALANCING MACHINE FOR AEROSPACE ROTORS

FEATURES

- Unbalance measurement according to SAE ARP4162 and ARP4048, suitable for high-speed rotating components with minimal tolerances.
- Horizontal configuration with saddle bearings (SAE cradles) and dual drive system (belt and/or cardan).
- For the balancing of complete engine modules - including fan, booster, LPC, HPC, HPT, and LPT - and for APU balancing.

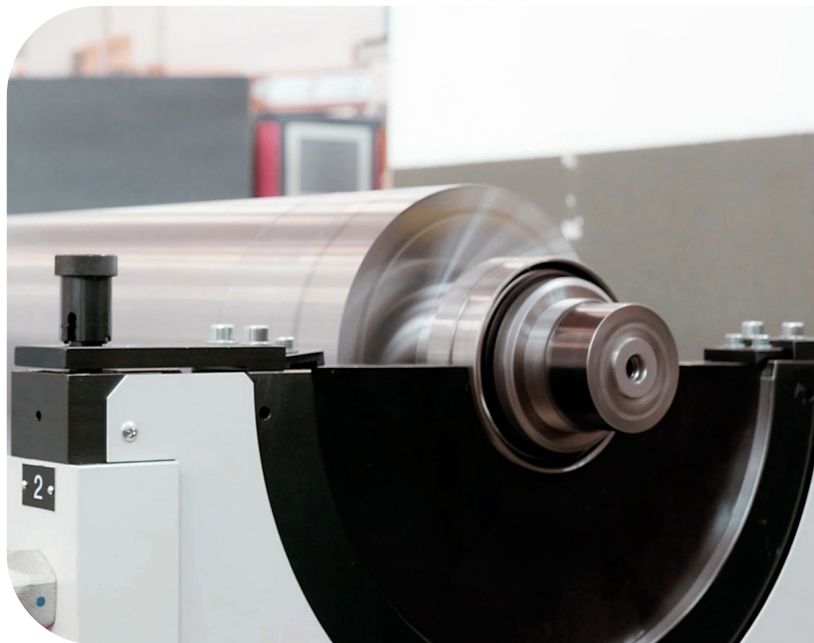

TECHNICAL DATA

	Z20 AERO	Z100 AERO	Z750 AERO	Z2000 AERO	Z5000 AERO
Maximum rotor weight (kg-lb)	30-66	150-330	1100-2420	3000-6600	6000-13200
Maximum rotor diameter (mm-inches)	360	1000	1600	1600	3000
SAE master (lb)	11	50	50	150	500
Machine SAE class	30	100	300	1000	3000

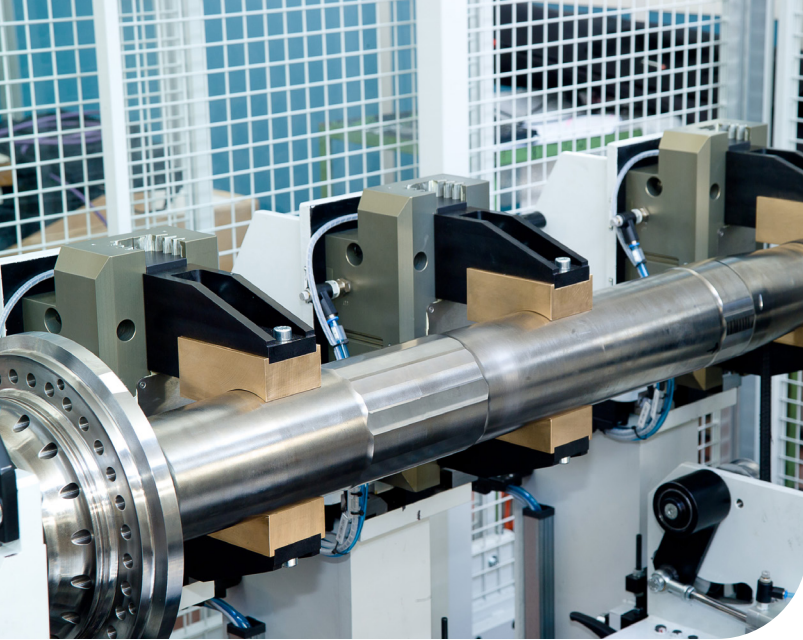

AUTOMATIC BALANCING MACHINE FOR **JET** ENGINE SHAFTS

—○ FEATURES

- Fully automatic balancing process, from unbalance detection to correction, with no need for manual intervention.
- Correction by direct milling on superalloys, specifically designed for aerospace applications.
- Three-plane balancing, essential for modern high-complexity jet engine shafts.

—○ TECHNICAL DATA

ZBK200/TO/S/AERO	
Maximum rotor weight (kg)	200
Maximum rotor diameter (mm)	500
Length of the bedplate (mm)	3050



BALANCING MACHINE FOR **HELICOPTER** DRIVE SHAFTS

—○ FEATURES

- Unbalance measurement suitable for high-speed rotating shafts, with flexible behavior and minimal tolerance.
- Horizontal configuration with high-rigidity bedplate and drive via electro-spindles.
- Specialized software for high-speed (supercritical) and multi-plane balancing.

—○ TECHNICAL DATA

ZB20/MS/AERO/S	
Maximum rotor weight (kg-lb)	20-44
Maximum rotor diameter (mm-inches)	220-8,66
Maximum rotor length (mm-inches)	4500-177,16

CUSTOM TOOLS

SAE ARP4163 balancing tooling and pneumostatic toolings: CEMB can supply high-precision special equipment to balance aerospace rotors.

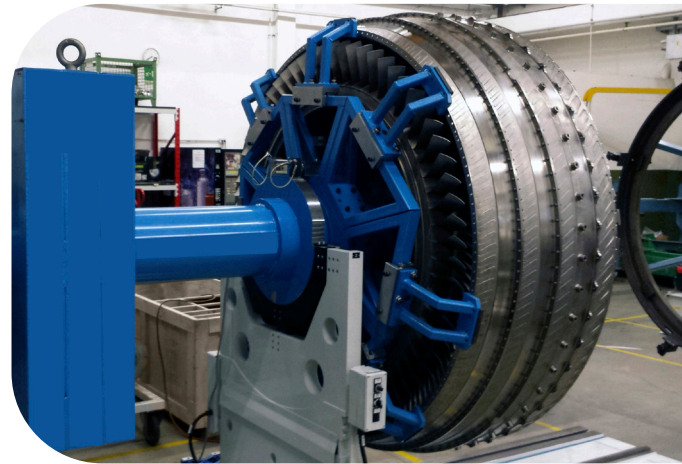
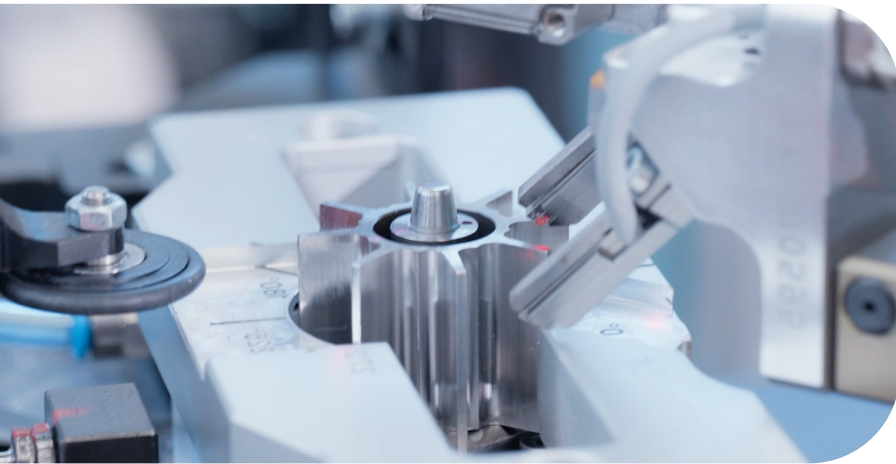

SAFETY GUARDS

The safety guard is designed to ensure a working environment compliant with the requirements of the Machine Directive 2006/42/EC, providing effective containment of the operating area and a high level of protection for both operators and equipment. The enclosed cabin fully surrounds the working area and incorporates dedicated openings that allow loading, unloading, and maintenance operations without compromising process safety.

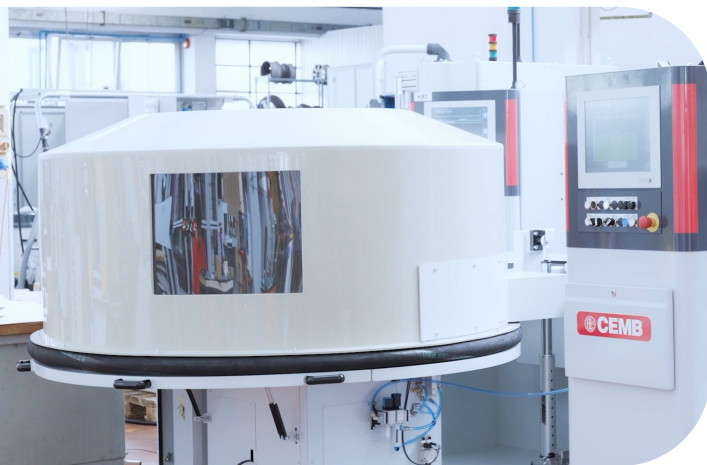

DEDICATED SOFTWARE

The measurement instrumentation is equipped with software dedicated to the aerospace industry, designed for multi-plane rotor balancing (from 2 up to 12 planes). A distinctive feature is the high level of customization, allowing full adaptability to the specific operational needs of OEMs and MROs, ensuring maximum flexibility and integration across different application environments.



CEMB S.p.A.
Via Risorgimento, 9
23826 Mandello del Lario (LC) - Italy
www.cemb.com

 Industrial balancing division
Plant and Training Center
+39 0341 706 111
industry@cemb.com